

FEATURES

- Two independent high performance linear servo amplifiers control DC brush motors torque and voice coil or linear motors force
- Linear operating mode does not emit EMI, has high servo stiffness, and no dead zone
- DSP platform provides programmable configuration, fault protection, self-test, calibration, and status reporting via RS232 port
- Current loop bandwidth and the transconductance, amps/volt scale factor, are adjustable
- Fault protection for amplifier SOA, over and under voltage, temperature, current overloads, and motor shorts
- Digital inputs for Enable/Reset, and (4) programmable functions
- Accepts analog command signals from a digital motion controller
- Operates with low inductance motors
- Operates from one low cost unregulated DC power supply with optional internal $\pm 12V$ DC-DC converter

APPLICATIONS

- Active isolation systems
- Linear stages, theta and Z-axis
- Integrated circuit manufacturing and inspection
- Air bearings, gantry systems
- High accuracy assembly / measurement
- Optical positioning and scanners
- Robotic processes



PRODUCT DESCRIPTION

This size 3U EUROCARD provides dual amplifier closed loop four quadrant torque or force control of DC brush rotary servo, torque motors, linear motors, and voice coil actuators.

Linear control of DC brush or linear motors is especially important for high performance position or velocity control systems. The pure DC form factor allows high current loop bandwidth.

The linear operating mode is highly advantageous for noise sensitive applications because it does not generate EMI. PWM switching noise is difficult to eliminate from sensitive sensors and transducers. This degrades velocity and position accuracy.

Excessive power dissipation is the main reliability consideration for linear amplifier operation. This model uses a digital signal processor (DSP) to monitor the junction temperature and safe operating area (SOA) of the output devices to prevent them from overheating and failing.

Operating status reports for each amplifier's (output volts, amps, power dissipation, and junction temperature) is available via RS232 connection.

GENERAL SPECIFICATIONS

MODEL# →	6-200-048-59
POWER AMPLIFIER	Linear Mode Drive
PEAK OUTPUT POWER	195 watts ¹
PEAK OUTPUT CURRENT	9 amps ¹ (1 sec typ.)
CONT. OUTPUT CURRENT	Note 1
MAX AMPLIFIER DISSIPATION	50 watts ¹
OUTPUT VOLTAGE @ PEAK CURRENT	38V with 48V Nominal bus
INPUT POWER BUS ⁵	24 to 60 VDC MAX
ANALOG SUPPLY ²	+12 VDC/0.2AMPS MAX
ANALOG SUPPLY ²	-12 VDC/0.2AMPS MAX
INPUT LOGIC SUPPLY ²	5 VDC / 0.3 AMPS MAX
COMMAND SIGNAL INPUT	± 10V differential
OPERATING TEMPERATURE	0 TO 50 Degrees C ¹
CURRENT COMMAND S.F.	1 or 0.5 AMP/VOLT
CURRENT LOOP BANDWIDTH	Adjustable 0.5 to 4 KHZ
SIZE	100 W x 220 L x 45 H mm
WEIGHT	.68 kg (1.5 lb)

OPERATING CONTROL SIGNALS and INDICATORS

Input analog A & B control signal ³	± 10 Volts differential
Peak current limit	Adjustable
Drive Enable/Reset	5V logic
Combination Fault Bit ³	5V logic
Four programmable I/O's (composite both Amplifiers)	5V logic
Fault indicator (composite both Amplifiers)	RED LED
Amplifier Enabled (composite both Amplifiers)	GREEN LED
Power Good (composite both Amplifiers)	2 GREEN LEDS

AUXILIARY OUTPUTS

Motor current monitor - Analog Signal
Drive status 4 outputs - Digital

SERIAL I/O

RS232
I²C

FAULT PROTECTION CIRCUITS

Power device junction temperature (SOA)
Short circuit
Over temperature ⁴
Over current ⁴
Over / under voltage

NOTES:

1. Depends on ambient operating temperature, motor winding resistance, and heat sink airflow. For the rated maximum power dissipation of 50 watts per amplifier or 100 watts total for both amplifiers, forced convection cooling with a minimum airflow of 100 CFM is required. Derate at 3 watts/degree C for ambient greater than 30 degrees C. Maximum controller dissipation occurs when the power out is minimum (motor stalled). It can be calculated as follows:

$$\begin{aligned}P_d &= P_{in} - P_{mtr} \\P_{in} &= (V_s)(I_o) \\P_{mtr} &= (I_o)^2(R_t)\end{aligned}$$

Where

P_d is controller dissipation in watts
 P_{in} is input power
 P_{mtr} is motor dissipation in watts
 V_s is supply voltage
 I_o is output current in amps
 R_t is motor terminal-to-terminal resistance in ohms.

Consult factory for assistance.

2. Optional internal DC – DC converter is available for applications requiring only one power supply to the amplifier.

3. Amplifier combinational fault bit.
A=B=1=NO FAULT
A=0,B=1=OVER CURRENT
A=B=0=OVER TEMPERATURE OR POWER LOSS

4. Over temperature or over current protection is determined from the DSP monitoring of amplifier operating heat sink temperature and output device power dissipation magnitude versus time. When power device junction over temperature protection is activated, the amplifier output will be disabled. A fault report is available via the RS232 port.

5. The user should protect the Amplifier and any external circuits from a catastrophic failure by fusing the input power connections to the amplifier. See Application Note Supplementary Fuse Protection (which can be viewed at www.peakservo.com).

EXTERNAL SIGNALS AND INTERCONNECTIONS

EDGE CONNECTOR J1 IS A 48 POLE DIN 41612 SERIES F
(REF EPT P/N 109-40064) or (FCI P/N 5159009486394111)

TERMINAL	SIGNAL NAME	DESCRIPTION
J1-2D, B, Z	NO CONNECTION	
J1-4D, B, Z	CONVERTER DC RTN	RTN TO +/- 12V DC/DC CONVERTER
J1-6D, B, Z	CHANNEL A DRIVE +	CHANNEL A + OUTPUT TO MOTOR WINDING
J1-8D, B, Z	CHANNEL A DRIVE -	CHANNEL A - OUTPUT TO MOTOR WINDING
J1-10D	DS1	OPTIONAL DIGITAL I/O
J1-10B	CHA CMD +	DIFFERENTIAL ANALOG \pm 10V CHA INPUT COMMAND, <1>
J1-10Z	CHA CMD -	DIFFERENTIAL ANALOG \pm 10V CHA INPUT COMMAND, <1>
J1-12D	DS2	OPTIONAL DIGITAL I/O
J1-12B	AMP ENB	AMPLIFIER ENABLE (=0) <2> <3>
J1-12Z	VCC FLD	DIGITAL POWER AND FAULT POWER <6>
J1-14D	FAULT A	AMPLIFIER COMBINATIONAL FAULT BIT <4>, <5>
J1-14B	FAULT B	AMPLIFIER COMBINATIONAL FAULT BIT <4>, <5>
J1-14Z	DGND	DIGITAL GND
J1-16D	CHA CURMON +	CHANNEL A CURRENT MONITOR +, SF V/A <8>
J1-16B	CHA CURMON -	CHANNEL A CURRENT MONITOR -, SF V/A <8>
J1-16Z	NO CONNECTION	
J1-18D	- 12VDC	- 12VDC POWER <7>
J1-18B	DS3	OPTIONAL DIGITAL I/O
J1-18Z	NO CONNECTION	
J1-20D	+12VDC	12VDC POWER <7>
J1-20B	DS4	OPTIONAL DIGITAL I/O
J1-20Z	NO CONNECTION	
J1-22D	CHB CURMON +	CHANNEL B CURRENT MONITOR +, SF V/A <8>
J1-22B	CHB CURMON -	CHANNEL B CURRENT MONITOR -, SF V/A <8>
J1-22Z	\pm 12V RTN	\pm 12VDC POWER RTN
J1-24D	CHB_CMD+	DIFFERENTIAL ANALOG \pm 10V CHB INPUT COMMAND, <1>
J1-24B	CHB_CMD-	DIFFERENTIAL ANALOG \pm 10V CHB INPUT COMMAND, <1>
J1-24Z	NC	RESERVED
J1-26D,B,Z	CHANNEL B DRIVE +	CHANNEL B + OUTPUT TO MOTOR WINDING
J1-28,D,B,Z	CHANNEL B DRIVE -	CHANNEL B - OUTPUT TO MOTOR WINDING
J1-30D,B,Z	+Vs DC POWER IN	+Vs POWER SUPPLY INPUT <9>
J1-32D,B,Z	+Vs DC POWER RTN	+Vs POWER SUPPLY RETURN

NOTES:

- <1> COMMAND POLARITY DETERMINES DIRECTION OF MOTION, SIGNAL AND SIGNAL RETURN CAN BE EXCHANGED.
- <2> OPTICALLY ISOLATED INPUT WITH INTERNAL 332-OHM PULL-UP RESISTOR TO 5VDC. SEE FUNCTIONAL DIAGRAM.
- <3> SWITCH S1 ON PCB IS IN SERIES WITH THIS LOGIC INPUT CMD. INSTALLATION OF JUMPER JP1 WILL DISABLE THE EXTERNAL CMD.
- <4> AMPLIFIER COMBINATIONAL FAULT BIT.
 - A=B=1=NO FAULT
 - A=0,B=1=OVER CURRENT
 - A=B=0=OVER TEMPERATURE OR POWER LOSS
- <5> OUTPUT FROM OPTO ISOLATOR COLLECTOR WITH INTERNAL 10k PULL-UP TO 5VDC. SEE FUNCTIONAL DIAGRAM.
- <6> VCC FLD CAN BE CUSTOMER SUPPLIED 3.3 OR 5 VDC OR USE INTERNAL 5V. SEE FUNCTIONAL DIAGRAM.
- <7> NOT REQUIRED WHEN OPTIONAL DC-DC CONVERTER IS ORDERED.
- <8> SCALE FACTOR VARIES WITH MODEL.
- <9> SEE APPLICATION NOTE SUPPLEMENTARY FUSE PROTECTION.

EUROCARD SERIES 59, 2-AXIS LINEAR DC SERVO AMPLIFIER

MOUNTING DIMENSIONS

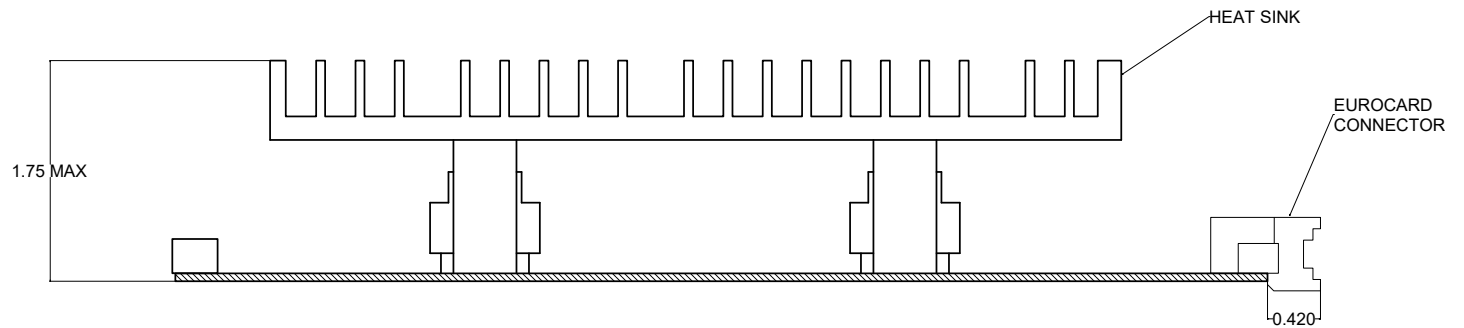
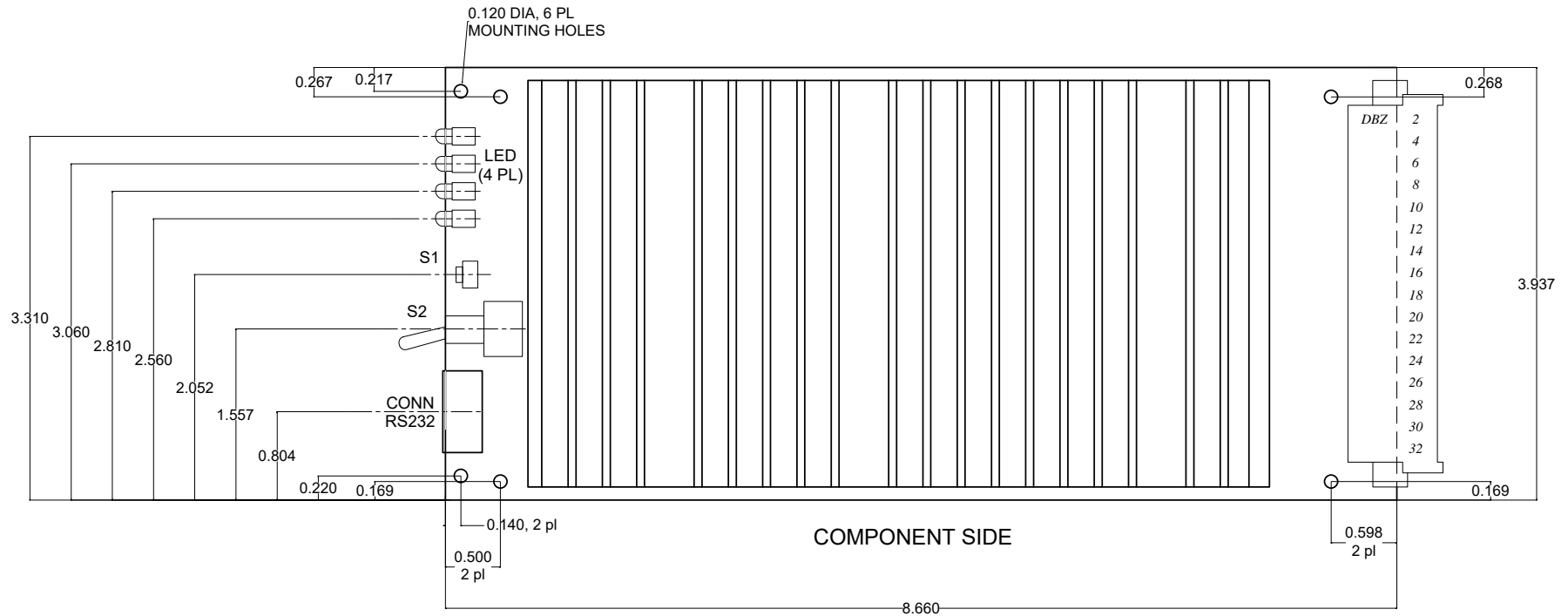

NOTES: 1. ALL DIMENSIONS SPECIFIED IN INCHES
 2. DO NOT SCALE

PEAK SERVO CORPORATION	
CARLSBAD, CA	
Title	
SERIES 59 - MOUNTING DIMENSIONS	
Document Number	Rev
3900059 OUTLINE.TCW	--
Date	
September 23, 2008	Sheet 1 of 1